The background of the slide is a dark blue abstract design with swirling, ribbon-like shapes and a fine grid pattern. A horizontal band with a slightly darker blue grid pattern is overlaid across the center, containing the title text.

# **New Generation Nuclear Energy: Spent Fuel Storage and Transport Considerations**

**Charles W. Pennington**

**Vice President**

**NAC International**

**American Enterprise Institute Nuclear Power Conference**

**October 6, 2006**

# **New Generation Nuclear Energy (NewGen): Spent Fuel Storage and Transport Considerations Topics for Discussion**

- **NAC Background**
- **NewGen Storage and Transport Needs**
- **Strengths, Threats, Opportunities**
  - **Storage/Transport Technology Strengths**
  - **Threats to NewGen, Storage and Transport**
  - **Opportunities to Counter Threats**
- **Recommended Policy Redirection**
- **Summary and Conclusions**

# NAC INTERNATIONAL OVERVIEW

*Proven Nuclear System and Service Solutions*

**Corporate Headquarters Near Atlanta, GA**

**Recognized Authority on Nuclear Fuel Cycle**

**3600 Cask Shipments Over 6 Million Miles**

**Manager of U.S. Nuclear Materials Tracking Database**

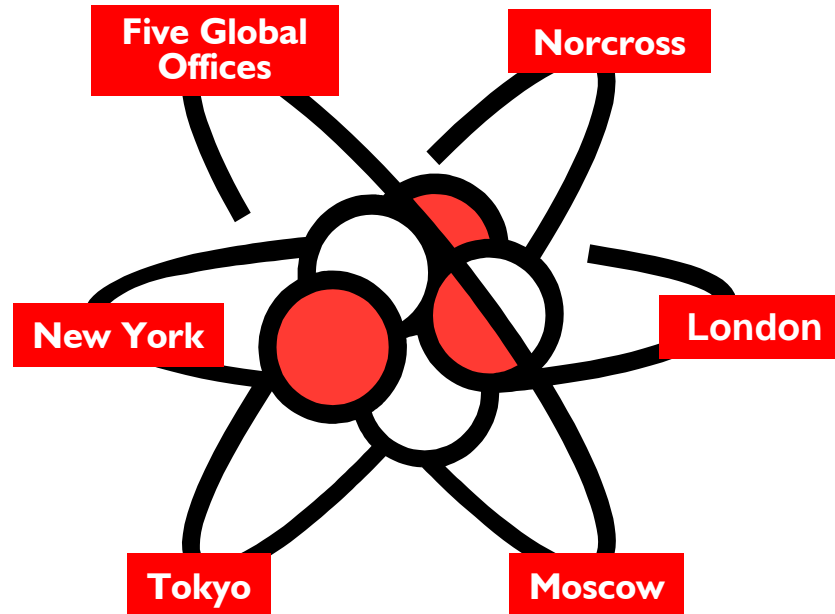

**Numerous Spent Fuel Storage/Transport Designs Licensed**

**Numerous Spent Fuel Storage/Transport Systems Deployed**

**Cask Services at Sites**

**Nuclear Fuel Data Management**

**Nearly 40 Years of Nuclear System and Service Solutions Experience**

NAC International is a Wholly Owned Subsidiary of USEC Inc., a Leading Supplier of Enriched Uranium Fuel for Commercial Nuclear Power Plants

# The Need for NewGen: Our Energy Present to This Generation

*U.S. Energy Usage by Source: 2001*

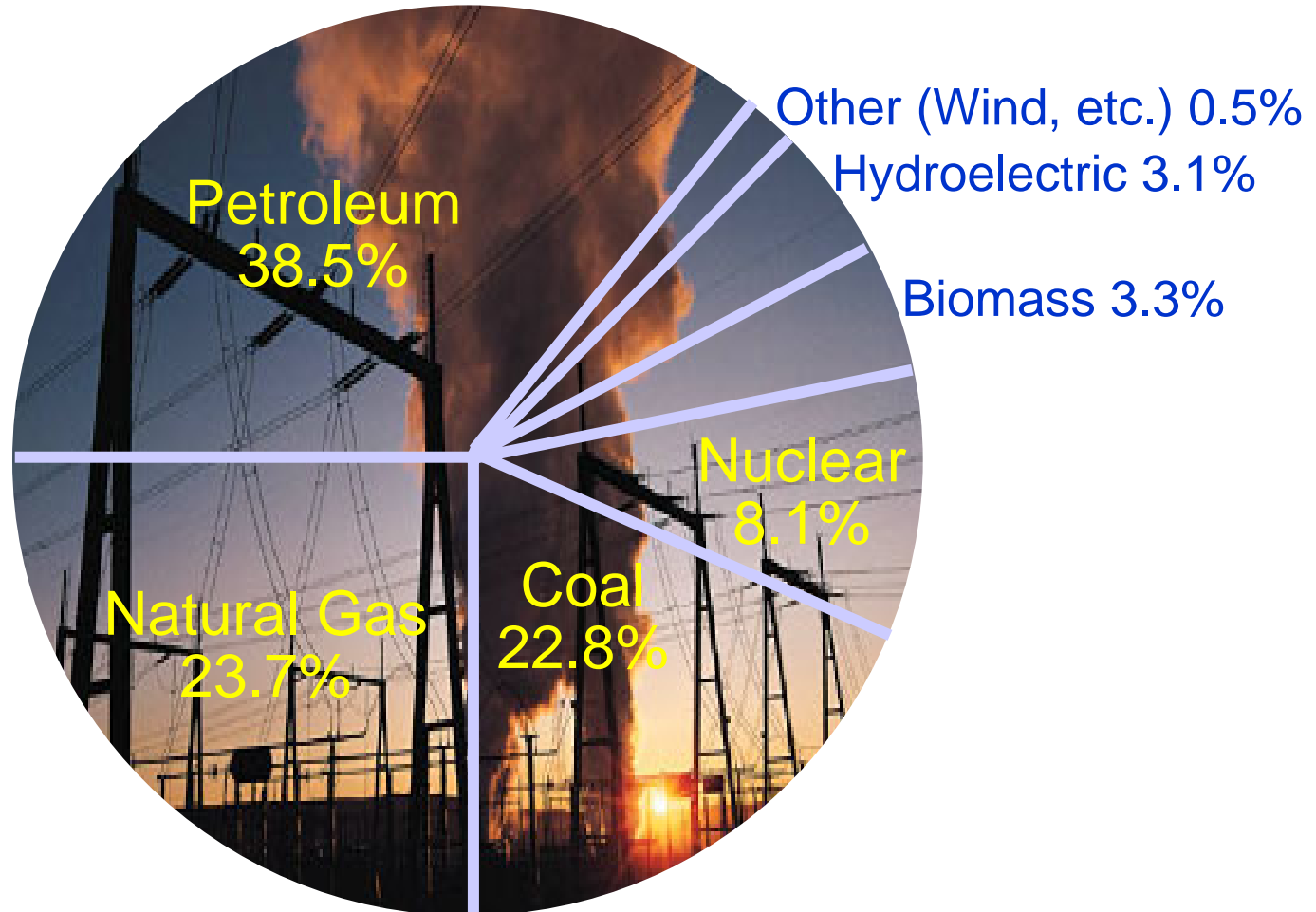

**Fossil Fuel Usage = 85% !!!**

# The Need for NewGen: Our Great Grandchildren's Energy Future

*U.S. Energy Availability by Source: ~2100*

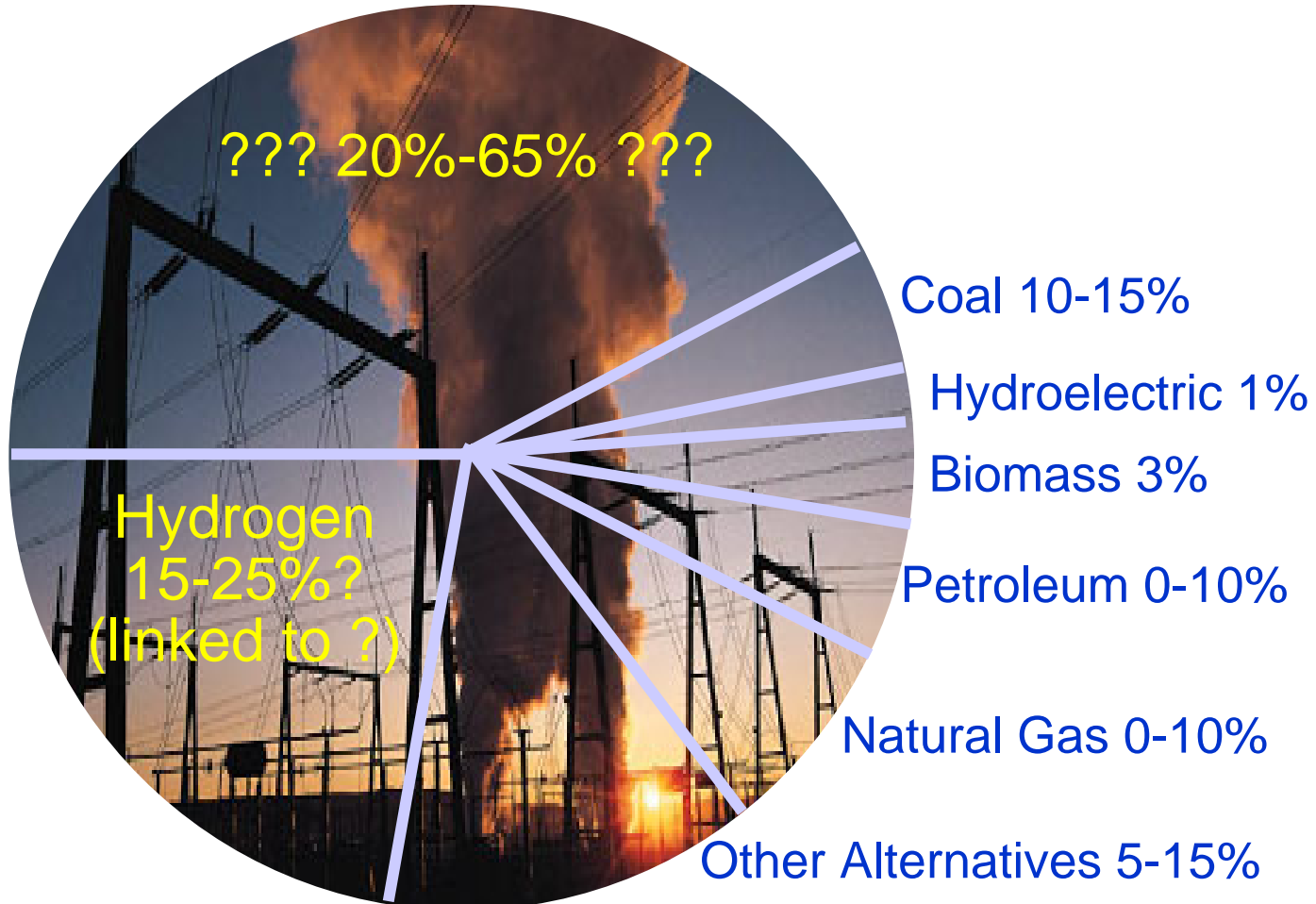

# **NewGen Spent Fuel Storage and Transport Needs**

- **NewGen like NowGen: it generates spent fuel**
- **Fuel and systems: NewGen poised to proceed**
- **Other NewGen needs:**
  - **Wet and dry storage technologies at plants,  
~10 years of wet storage, rest in dry storage**
  - **Transport technology to move spent fuel**
  - **Closure of once-through fuel cycle with  
opening of Yucca Mountain (YM)**
  - **Interim storage before and after YM opens**
- **Can storage and transport support NewGen?**

# Dry Storage/Transport Technology Strengths

- **Technology Experience**
  - Dry spent fuel storage
  - Dry spent fuel transport
- **Technology Robustness**
  - Accidents
  - Militant Acts of Destructiveness (MADness)

## **Dry Spent Fuel Storage: Extensive Experience**

- **Many NRC licensed systems for dry storage (NAC by itself has five)**
- **Licensing process proven and successful**
- **20 years of reactor dry storage experience**
- **High burnup fuels already addressed**
- **More than 870 dry storage units in use at reactor and government sites**
- **The National Academy of Sciences (NAS) has recognized dry storage safety and advocated consideration of early dry storage of spent fuel**

# Dry Spent Fuel Storage Proven Technology

Vertical Metal



Vertical Concrete



Horizontal Concrete

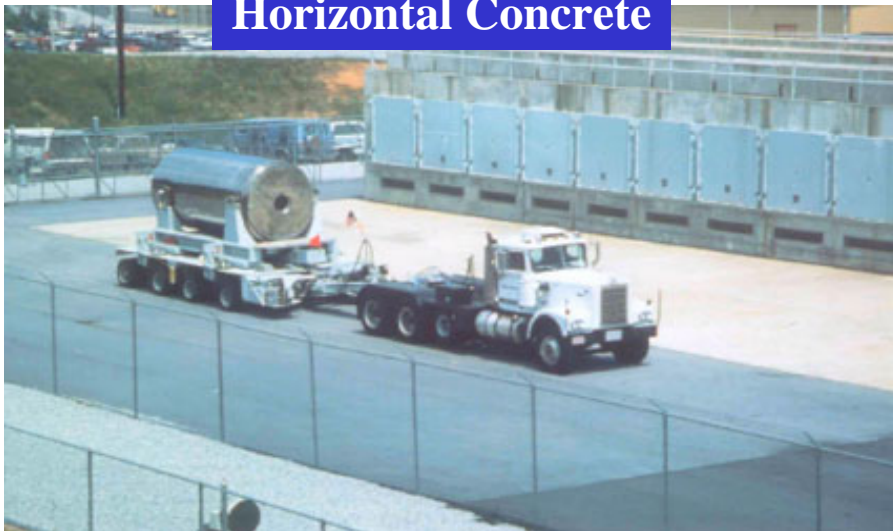

## **Dry Spent Fuel Transportation: Extensive Experience**

- **Many NRC licensed transportation systems (NAC by itself has four)**
- **Licensing process proven and successful**
- **Experience shows transportation protocols well-understood for safety and security**
- **Excluding military, more than 4,000 safe spent fuel shipments in the U. S. over the last 4 decades (average of about 2 per week).**
- **NAS says no technical barriers to safe transport, but social issues may arise for large campaigns**

# Recent NAC Research Reactor Experience

- Texas A&M, TX
- Demokritos, Greece
- Graz, Austria
- SUNY, Buffalo, NY
- NRG Petten, The Netherlands
- UMass, Lowell, MA
- UIUC, Urbana-Champaign, IL
- UT, Austin, TX
- Serpong, Yogyakarta, and Bandung, Indonesia
- Cornell University, NY
- NIST, MD
- Brookhaven National Lab, NY



# NAC U. S. Nuclear Power Plant Transportation Experience

<b>Limerick</b>	<b>Summer</b>	<b>...and more</b>
<b>North Anna</b>	<b>Ginna</b>	
<b>Oconee</b>	<b>North Anna</b>	
<b>Robinson</b>	<b>Cooper</b>	
<b>Duane Arnold</b>	<b>San Onofre</b>	
<b>LaSalle</b>	<b>Callaway</b>	
<b>Browns Ferry</b>	<b>Point Beach</b>	
<b>Watts Bar</b>	<b>St. Lucie</b>	
<b>Hatch</b>	<b>Calvert Cliffs</b>	
<b>Oyster Creek</b>	<b>Lacrosse</b>	
<b>Maine Yankee</b>	<b>CT Yankee</b>	
<b>Braidwood</b>	<b>Ft. Calhoun</b>	
<b>ANO</b>	<b>Hope Creek</b>	

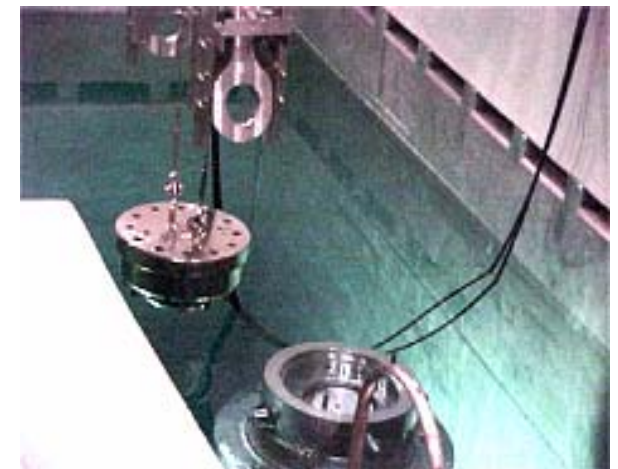

# Dry Spent Fuel Transport Proven Technology

## Truck Cask

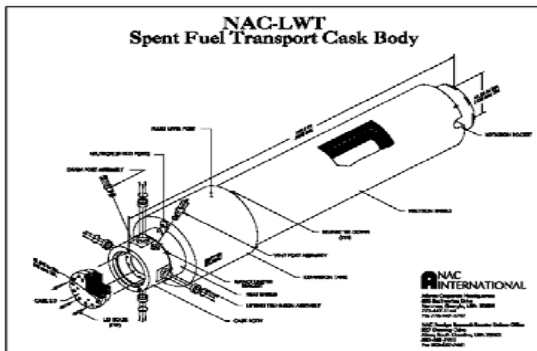

## Rail Cask

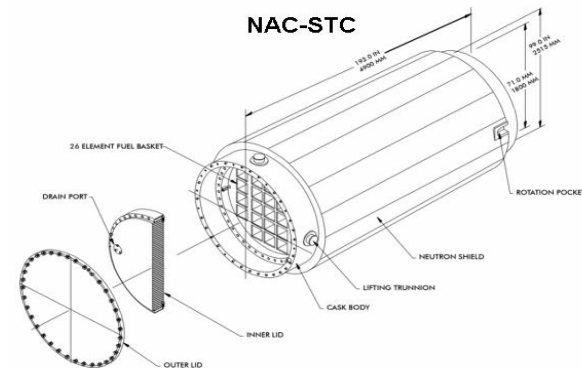

## **Summary: Truck, Rail, and Marine Spent Fuel Transportation Experience**

- **Extensive experience over 40 years shows that spent fuel transportation**
  - **Is routinely accomplished safely and securely**
  - **Is performed on schedule and budget**
  - **Success is a learned, repeatable process**
  - **Methods to assure success are in place**
- **Safe, secure spent fuel transport to support NewGen for YM and interim storage is well founded on this successful experience**

# Spent Fuel Storage/Transport Technology Robustness

- **Spent fuel less threatening than most HazMat**
  - **Clad ceramic fuel not readily dispersed in high concentrations**
- **Unique design conservatism due to regulations on radiation**
  - **Structural conservatism from gamma and neutron shielding materials that must remain part of packaging**
    - **add structural, impact protection to containment and seals**
    - **add thermal resistance/protection to containment and seals**
  - **Conservative codes/standards, regulatory interpretations**
- **Result: spent fuel cask safest HazMat packaging under all accident conditions**
- **Extensive cask testing over 30 years shows great robustness under**
  - **Real world accidents, hypothetical accidents, MADness events**

# Transport/Storage System Materials: Safety Margins Against Failure

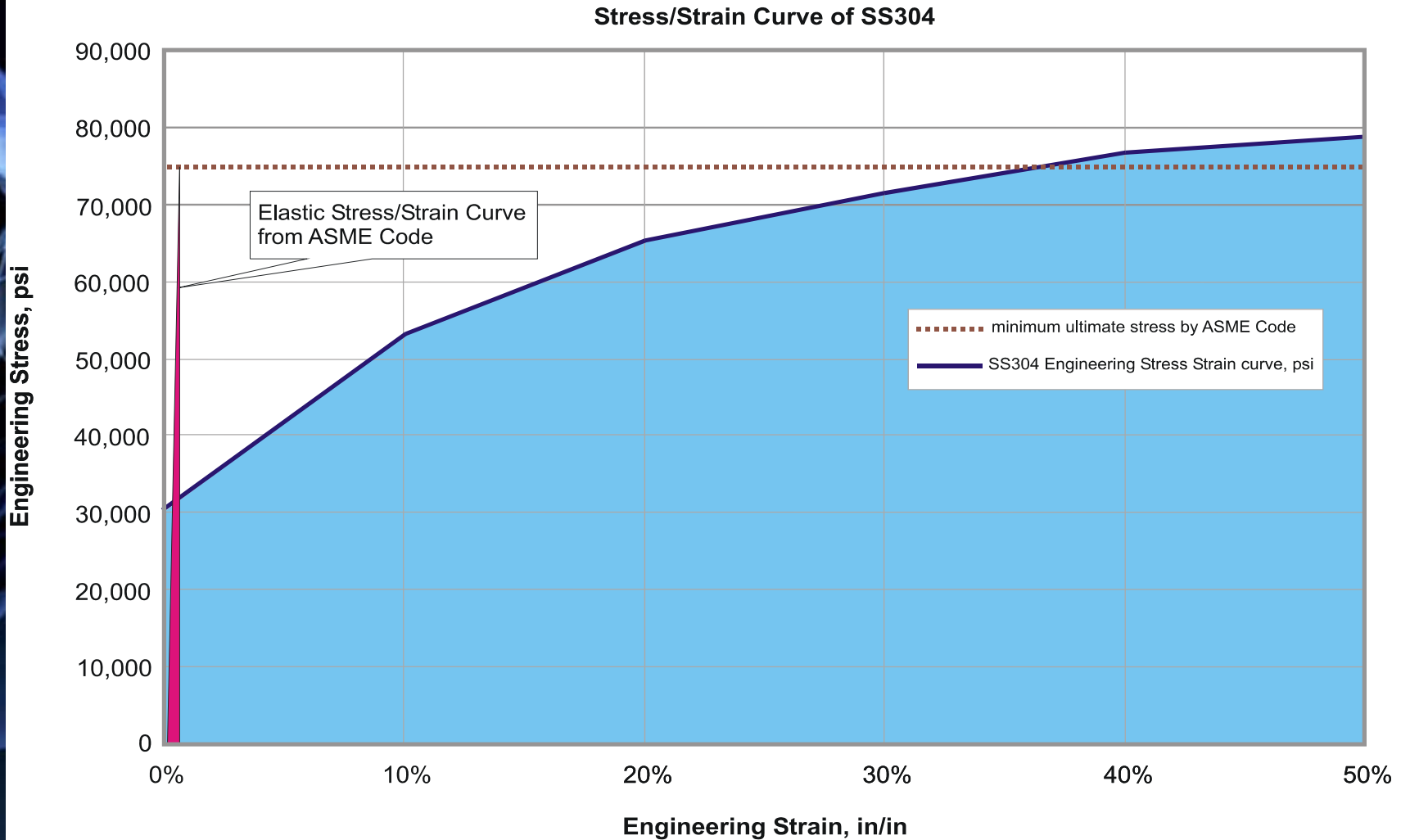

# Transport/Storage System Response to MADness Events

- **Large safety margins under normal, off-normal and accident events:**  
*no release of radioactive materials*
- **MADness events assessed for transport/storage systems:**
  - **conventional impacts/fire**
  - **Explosives and weapons**
- **Testing and analysis over 30 years show radioactivity release is almost impossible, but exposures below other normal exposures**

**Conclusion: experience with and robustness of storage/transport systems well demonstrated.**

# Threats to NewGen: Storage and Transport

Among several others, two addressed herein

## Long-term

**Fear campaigns stimulating public opposition**

- **proven very effective against nuclear, leading to loss of public support, political reversals,**

## Near-term

**NRC's Beyond Design Basis Threat (BDBT) ruling**

- **Mothers for Peace/Ninth Circuit Court decision on MADness in Environmental Impact Statements (EIS) also relevant**

# Nuclear Energy: Counsel From the Past

**Nuclear energy ain't so new  
and it ain't so clear!**

*– Howland Owl (Walt Kelly – Pogo)*

## Opportunities: Educate Early to Foster Public Understanding

*If NewGen is to succeed over a long period:*

- Primary task: broad public education with clarity of message addressing needs and fears
- Industry and DOE develop strategy, implement public education (starting now)

Example of one aspect of education: address the fear of nuclear energy

- Whether concern is environmental, operations, accidents, spent fuel storage/transport, or waste disposal, fear of fission is founded on perception of a singular hazard associated with nuclear

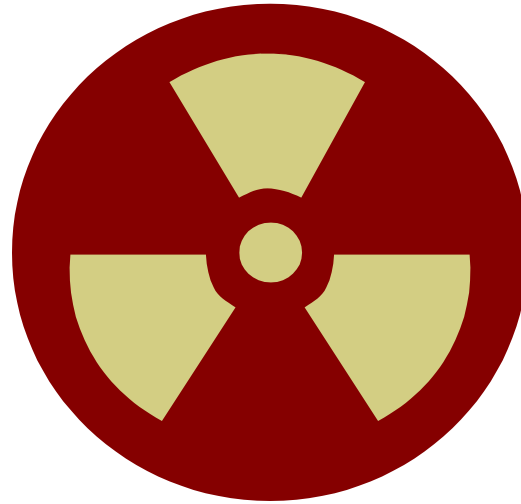

Simply stated, fear of nuclear energy is a learned response to education that nuclear energy presents a *unique and highly elevated* threat from

 **RADIATION** 

**A public perception shift is required.**

## **Public Education: A Vote of Confidence**

**I am a firm believer in the people. If given the truth, they can be depended upon to meet any national crisis. The great point is to bring them the real facts.**

**– *Abraham Lincoln***

## **One Aspect of the Education Approach**

- **Fear of nuclear is a learned response; “normalcy” of nuclear can also be learned**
- **Normalize the perception of nuclear in a radioactive world through widespread education**
- **Address fears of nuclear in a “compared to what” architecture**
- **Compare nuclear with “what’s normal” in other industries**

## What Do These Non-Nuclear Industries Have in Common?

- Building design/construction
- Agriculture
- Construction Materials
- Aviation
- Mining (many varieties)
- Waste processing  
of natural materials
- Fertilizer production/use
- Water treatment
- Geothermal energy uses
- Natural gas in homes
- Fossil fueled electricity
- Potable water supply
- Oil/gas production
- .. .and others

**Each produces high population exposures  
to ionizing radiation every year**

## **Normalizing Nuclear: One Approach Is Comparative Assessment**

- **These industries can deliver tens to hundreds of times more annual population exposure to ionizing radiation than the entire commercial nuclear fuel cycle**
  - **It's unregulated, unmonitored, unreported, and lognormally distributed**
  - **Nuclear energy results in a tiny fraction of the exposures from these industries**
- **Nuclear energy must be framed with this understanding of what's normal in the world**
- **Public education can provide such learning**

## **The Objective of Education: Winning Minds of New Generations**

**A scientific truth does not triumph by convincing its opponents and making them see the light, but rather because its opponents eventually die and a new generation grows up that is familiar with it.**

*– Maxwell Planck*

***Education Exorcises Fear***

## **Opportunities: NRC Beyond Design Basis Threat (BDBT) Ruling**

- **NRC should establish non-nuclear industry population exposures as one acceptance criterion for BDBT/MADness events**
  - **This is a reasonable and defensible standard**
- **Population exposure to ionizing radiation from non-nuclear industries has never been of sufficient concern to merit regulation**
- **BDBT/MADness events give lower exposures**

**Comparison With Non-Nuclear Industries  
Should Also Be Used Here**

# Recommendations for Policy Redirection

## Policy actions

- **Active bipartisan federal advocacy for NewGen**
- **Strong federal support for both childhood and adult education programs on NewGen**
- **Strong industry funding for and participation in education programs, integrated with federal efforts**
- **Reasonable, defensible acceptance standards for BDBT and MADness events for nuclear industry**

## Summary and Conclusions

- Safe and secure spent fuel storage and transport are ready to be part of NewGen
- Long term NewGen success depends on public acceptance
- Greatest threat to NewGen is fear-driven public opposition
- Public education must begin now; it may take a generation to establish firm public support
- Political vagaries will moderate with public education; *when the people understand, the politics will be right*

**In the end, is NewGen in our interest?  
This *WE* must finally decide!**

Atlanta Corporate Headquarters  
3930 East Jones Bridge Road  
Norcross, Georgia 30092  
770-447-1144  
Fax 770-447-1797

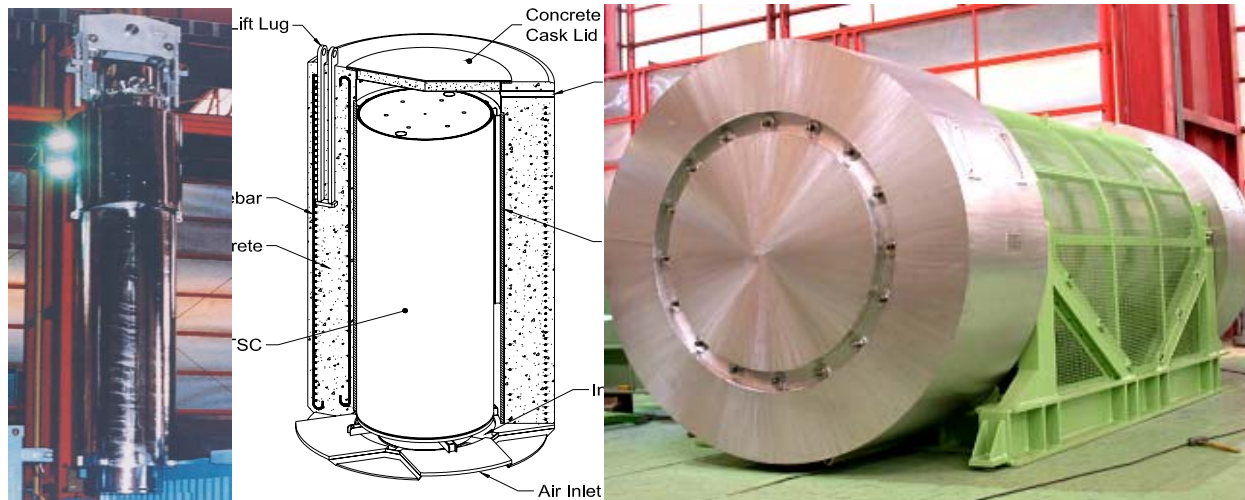

**The significant problems we face cannot be solved  
by the same level of thinking that created them.**

*– Albert Einstein*